

The FOX generating set range offers a very large application target with powers ranging from 9 to 24 kVA at 50 and 60Hz. The new compact and sturdy design and maximum noise reduction make it suitable for all construction sites and home backup power supply, both mobile and stationary. Well-supplied equipment and a large range of accessories are available for customization. The new FOX includes the standard Guard Revolution control panel and is equipped with a large display screen, emergency button, ignition barrel and circuit breaker. As with all Onis Visa products, all the unit's parts are subject to a strict operating test involving over 30 checks prior to delivery.

ENGINE

Industrial engine, complete with cooling system, injection system with automatic speed regulator, electrical ignition system and battery charger



ALTERNATOR

Industrial, brushless alternator with electronic voltage control system



CONTROL UNIT

The Control Panel range allows you to monitor and control your generating set with ease, whilst ensuring your unit operates within safe parameters and provides important diagnostic information when needed.



STANDARD CONTROL PANEL

GUARD REVOLUTION

OTHER BRANDS AVAILABLE



STANDARD EQUIPMENT

- Load bearing baseframe with liquid retention basin
- High damping anti-vibration mounts placed between the engine/alternator and baseframe
- 50 l fuel tank with electronic level sensor, plugs. Loading and unloading
- Engine oil extraction pump
- Fuel decanter filter
- Sound-insulated canopy made with galvanised and painted sheet metal
- Key-locks on the doors
- Fire-reaction Euroclass Bs2D0 fireproof polyester sound-proofing
- Highly-insulating pad on the internal exhaust pipe
- Automobile-type gasket with steel core (non adhesive)
- High sound insulating exhaust silencer
- Rain cap
- Lifting points on all 4 sides (and overlapping for delivery)
- Set-up for quick fuel release fittings (auxiliary, external tank connection)
- Battery cut-off switch (only in the CE version).

OPTIONAL EQUIPMENT

- External sockets
- Additional air intake panels on the P14 and P21 models
- Oversize fuel tank
- Retention basin for oversize fuel tank
- AMF automatic panel and auto start
- ATS changeover switch panel
- Radiator liquid level sensor
- 220v electric pre-heater
- PW005 terminal board for separate electrical panel
- Canopy colour can be requested if different from RAL yellow 1007 or RAL white 9010
- Slow moving trailer





SERIES: **FOX** VERSION: **SOUNDPROOF** RANGE: **9-20** kVA

ENGINE:		Perkins			ALTERNATOR:			STAMFORD			FROM 9 TO 20 kVA					
MODEL	P.R.P. kVA	L.T.P. kVA	ENGINE	REG.	ALTERNATOR	BASEFRAME	CANOPY	W mm	L mm	H mm	WEIGHT Kg	TANK SIZE L	OVERSIZED TANK SIZE L	CONS. 75% l/h	dBA at 7m	
P 9 FOX	9	10	403A-11G1	M	PI044E	FOX	FOX	770	1470	1330	515	50	600-1000	2	62	
P 14 FOX	13,1	14,5	403A-15G1	M	PI044G	FOX	FOX	770	1660	1330	610	50	600-1000	2,8	63	
P 15 FOX	15	16,5	403A-15G2	M	PI044G	FOX	FOX	770	1660	1330	650	50	600-1000	3,1	63	
P 21 FOX	20	22	404A-22G1	M	PI144D	FOX	FOX	770	1660	1330	690	50	600-1000	4	65	

ENGINE:		Perkins			ALTERNATOR:			mecc alte			FROM 9 TO 20 kVA					
MODEL	P.R.P. kVA	L.T.P. kVA	ENGINE	REG.	ALTERNATOR	BASEFRAME	CANOPY	W mm	L mm	H mm	WEIGHT Kg	TANK SIZE L	OVERSIZED TANK SIZE L	CONS. 75% l/h	dBA at 7m	
P 9 FOX	9	10	403A-11G1	M	ECP3-1L/4	FOX	FOX	770	1470	1330	510	50	600-1000	2	62	
P 14 FOX	13,1	14,5	403A-15G1	M	ECP3-2L/4	FOX	FOX	770	1660	1330	580	50	600-1000	2,8	63	
P 15 FOX	15	16	403A-15G2	M	ECP3-3L/4	FOX	FOX	770	1660	1330	590	50	600-1000	3,1	63	
P 21 FOX	20	21,5	404A-22G1	M	ECP28-M/4	FOX	FOX	770	1660	1330	680	50	600-1000	4	65	

SINGLE PHASE																
ENGINE:		Perkins			ALTERNATOR:			STAMFORD			FROM 9 TO 20 kVA					
MODEL	P.R.P. kVA	L.T.P. kVA	ENGINE	REG.	ALTERNATOR	BASEFRAME	CANOPY	W mm	L mm	H mm	WEIGHT Kg	TANK SIZE L	OVERSIZED TANK SIZE L	CONS. 75% l/h	dBA at 7m	
P 9 FOX	8,4	9,2	403A-11G1	M	PI044F	FOX	FOX	770	1470	1330	524	50	600-1000	-	62	
P 14 FOX	13,1	14,5	403A-15G1	M	PI144D	FOX	FOX	770	1660	1330	675	50	600-1000	-	63	
P 15 FOX	15	16,5	403A-15G2	M	PI144E	FOX	FOX	770	1660	1330	690	50	600-1000	-	63	
P 21 FOX	18,7	20,6	404A-22G1	M	PI144F	FOX	FOX	770	1660	1330	690	50	600-1000	-	65	

FOX SMALL SIZE, BIG POWER

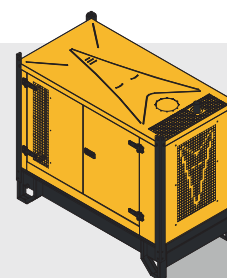

P 9 FOX
UP TO **46** UNITS IN 40' CONTAINER

P 14/21 FOX
UP TO **30** UNITS IN 40' CONTAINER

CONSIDERING A STANDARD GE VERSION WITH 50 L FUEL TANK

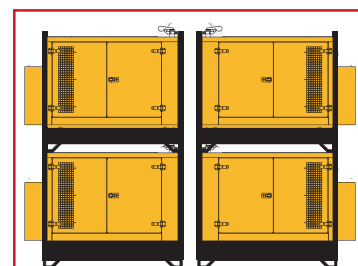

DOUBLE LAYER

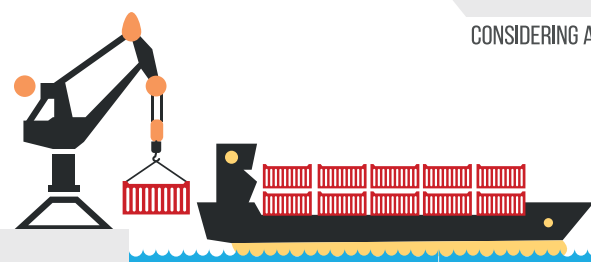

WORLDWIDE SHIPMENT





FOX serie gensets' family gets Bigger, Visa's smartest range expands its own power up to 60kVA, while always maintaining the specific features: compact and sturdy, low noise level and extremely versatile! Available from 20 to 60 kVA, provided with Deutz or Perkins engine, the BiGFOX can fully satisfy everyone's needs. Suitable for continuous or emergency service, for civil or industrial use, BiGFOX represents a reliable solution for all those projects where power as well as compact size are required. A wide choice of optional accessories is available to fully customize your BiGFOX. The new BiGFOX includes the standard Guard Revolution control panel and is equipped with a large display screen, emergency button, ignition barrel and circuit breaker. As with all Onis Visa products, all the unit's parts are subject to a strict operating test involving over 30 checks prior to delivery.

ENGINE

Industrial engine, complete with cooling system, injection system with automatic speed regulator, electrical ignition system and battery charger



ALTERNATOR

Industrial, brushless alternator with electronic voltage control system



CONTROL UNIT

The Control Panel range allows you to monitor and control your generating set with ease, whilst ensuring your unit operates within safe parameters and provides important diagnostic information when needed.



STANDARD CONTROL PANEL
GUARD REVOLUTION

OTHER BRANDS AVAILABLE



STANDARD EQUIPMENT

- Industrial diesel engine in genset version with certificate of origin
- Industrial brushless alternator with AVR
- Steel baseframe with retention basin, fuel tank with level sensor
- Soundproof canopy in galvanised, power coated sheet steel
- Soundproofing material made of high attenuation polyester fibre
- Internal exhaust silencer with insulated manifold
- Electrical panel mounted on board the unit with digital control device installed in metal box
- Compact for easy handling and use
- Test report, manuals and electrical drawings supplied
- World wide after sales service and technical support

Further details on the technical data sheet

OPTIONAL EQUIPMENT

- External sockets
- Additional air intake panels on the P14 and P21 models
- Oversize fuel tank
- Retention basin for oversize fuel tank
- AMF automatic panel and auto start
- ATS changeover switch panel
- Radiator liquid level sensor
- 220v electric pre-heater
- PW005 terminal board for separate electrical panel
- Canopy colour can be requested if different from RAL yellow 1007 or RAL white 9010
- Slow moving trailer





SERIES: **BigFOX** VERSION: **SOUNDPROOF** RANGE: **20-60** kVA

ENGINE:		Perkins		ALTERNATOR:				STAMFORD								FROM 30 TO 60 kVA			
MODEL	P.R.P. kVA	L.T.P. kVA	ENGINE	REG.	ALTERNATOR	BASEFRAME	CANOPY	W mm	L mm	H mm	WEIGHT Kg	TANK SIZE l.	OVERSIZED TANK SIZE l.	CONS. 75% l/h	dBa at 7m				
P 30 FOX	30	33	1103A-33G	M	PI144G	FOX	FOX3	945	2030	1470	1010	90	600-1000	5,4	63				
P 41 FOX	40	45	1103A-33TG1	M	PI144J	FOX	FOX3	945	2030	1470	1050	90	600-1000	8,2	63				
P 65 FOX	60	62	1103A-33TG2	M	UCI224E	FOX	FOX3	945	2200	1470	1190	90	600-1000	8,2	65				

ENGINE:		DEUTZ		ALTERNATOR:				STAMFORD								FROM 20 TO 60 kVA			
MODEL	P.R.P. kVA	L.T.P. kVA	ENGINE	REG.	ALTERNATOR	BASEFRAME	CANOPY	W mm	L mm	H mm	WEIGHT Kg	TANK SIZE l.	OVERSIZED TANK SIZE l.	CONS. 75% l/h	dBa at 7m				
D 21 FOX	20	21,3	F3M2011	M	PI144D	FOX	FOX3	945	2030	1340	830	90	600-1000	4	65				
D 30 FOX	30	33	F4M2011	M	PI144G	FOX	FOX3	945	2030	1340	910	90	600-1000	5,5	65				
D 41 FOX	40	44	BF4M2011	M	PI144J	FOX	FOX3	945	2030	1340	940	90	600-1000	7,4	65				
D 62 FOX	60	62	BF4M2011C	M	UCI224E	FOX	FOX3	945	2240	1340	1150	90	600-1000	10,4	68				

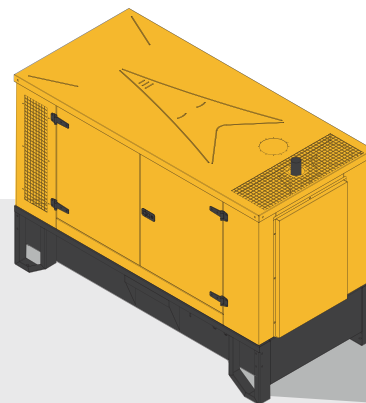

BigFOX COMPACT POWER



BigFOX (D21/D30/D41/D62)
UP TO **24** UNITS IN 40' CONTAINER HC

CONSIDERING A STANDARD GE VERSION WITH 90 L FUEL TANK

